

Wire Nesting Cart

This high quality, versatile cart can be used both by store personnel and your customers. Customers can use the cart for large items, while placing small purchases in the mid utility basket. These carts nest into less than 33% of their normal length, thus freeing up valuable floor space.



FEATURES:

- All welded steel construction
- Gusseted and reinforced in high stress areas
- Nestable for easy storage
- Mid Utility Basket (MB)
- Zinc Plated Finish

REPLACEMENT PARTS:

- (2) 5" x 1 1/4" casters. Replacement order #B000001. Fastener replacement order #B000332(nut)
- (2) 5" x 1 1/4" swivel casters. Replacement order #B00059. Fastener replacement order #B000673 (bolt), B000198 (nut) and B000606 (washer)
- (1) Bottom tray. Replacement order #5000567



Carts shown nested together



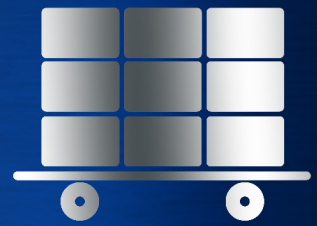

Material Handling

Freight Class: 175
 NMFC Code: 189430-S2

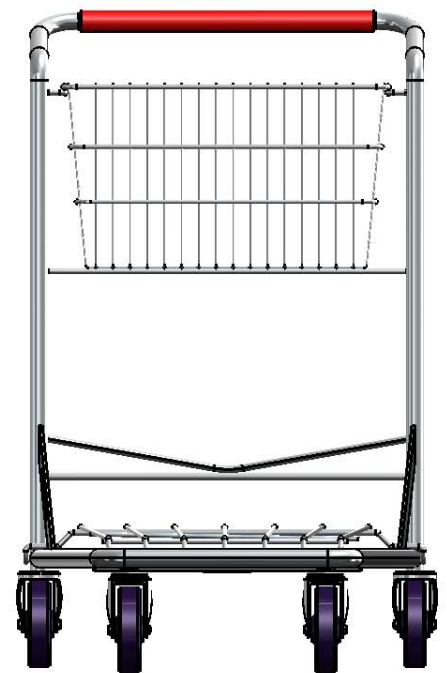
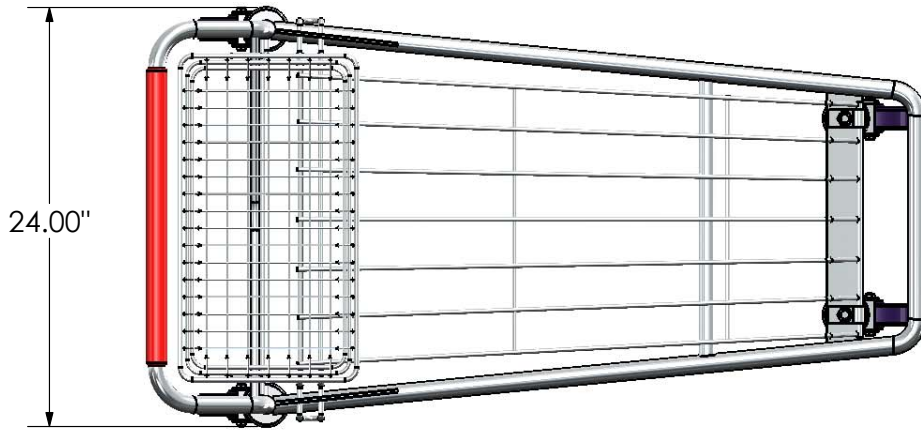

Order #	Model	W	L	H	Capacity	Weight
5000562	WIRE NESTING CART	24"	44 1/2"	37 1/2"	300 lbs.	32 lbs.

Can't find exactly what you need? Give us a call and we'll help you with the perfect solution!